

WOOD AND CHIPBOARD SCREWS

COUNTERSUNK HEAD POZI

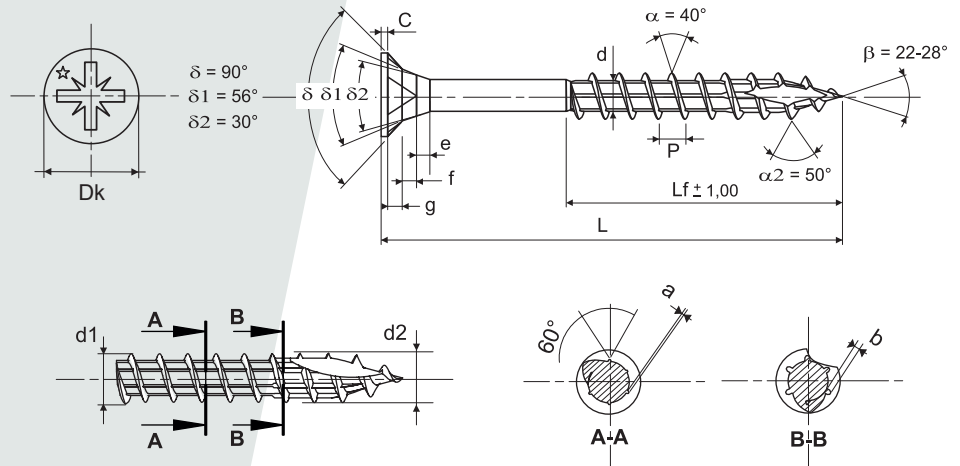

TECHNICAL CHARACTERISTICS

	Ø 3	Ø 3,5	Ø 4	Ø 4,5	Ø 5	Ø 6
Head depth	1,30 / 1,60	1,40 / 1,70	1,40 / 1,70	1,80 / 2,10	2,10 / 2,40	2,40 / 2,70
Screw driver	PZ1	PZ2	PZ2	PZ2	PZ2	PZ3
Dk	5,70 ± 0,20	6,70 ± 0,20	7,70 ± 0,20	8,70 ± 0,20	9,30 ± 0,20	11,30 ± 0,20
C	0,30 / 0,60	0,30 / 0,60	0,40 / 0,70	0,50 / 0,80	0,60 / 0,90	0,70 / 1,10
g	1,00	1,20	1,45	1,60	1,63	1,74
f	1,04	1,20	1,35	1,50	1,60	2,32
e	1,01	1,13	1,25	1,39	1,50	2,39
d	1,80 / 2,10	2,00 / 2,30	2,30 / 2,60	2,50 / 2,80	2,90 / 3,30	3,60 / 4,10
P	1,70 ± 10%	2,00 ± 10%	2,30 ± 10%	2,60 ± 10%	2,90 ± 10%	3,50 ± 10%
d1	2,95	3,45	3,95	4,45	4,95	5,95
d2	3,05	3,55	4,05	4,55	5,05	6,05
a/b	0,22 / 0,22	0,22 / 0,27	0,22 / 0,32	0,22 / 0,37	0,22 / 0,42	0,22 / 0,45

For ROCKET screws less than 25 mm, diameters d1 and d2 are identical.

All Ø	L = 12/16	20/30	35/50*	60/100**	110/120	130/180	200
Tolerance	0/-0,90	0 / -1,05	0 / -1,25	0 / -1,50	0 / -1,75	0 / -2,00	0 / -2,50

* except 6x40/22 = 0/-1,05

** except 4x80/45 - 5x90/50 - 5x100/60 = 0/-1,75
6x80/50 - 6x90/50 = 0/-1,25



EN 14592
+A1 2012

A2 stainless steel