

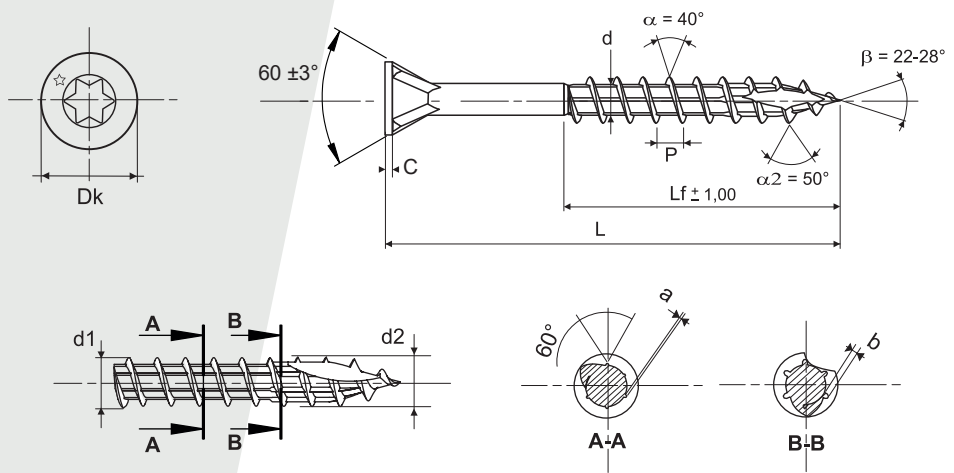

# FLOORINGS SCREWS

## COUNTERSUNK HEAD STAR



### TECHNICAL CHARACTERISTICS

	Ø 3,5
Head depth	1,40 / 1,70
Screw driver	T10
Dk	5,50 / 5,90
C	0,50 / 0,70
d	2,00 / 2,30
d1	3,45
d2	3,55
P	2,00 ± 10 %
Minimum breaking torque	2,60 Nm

Ø 3,5	Total length =	35	45/55
Tolerance	L	-1,05	L -1,25

\ Zinc coated steel