



TX 



EN 14592
+A1 2012

TERRASSE

TÊTE FRAISÉE EMPREINTE ÉTOILE

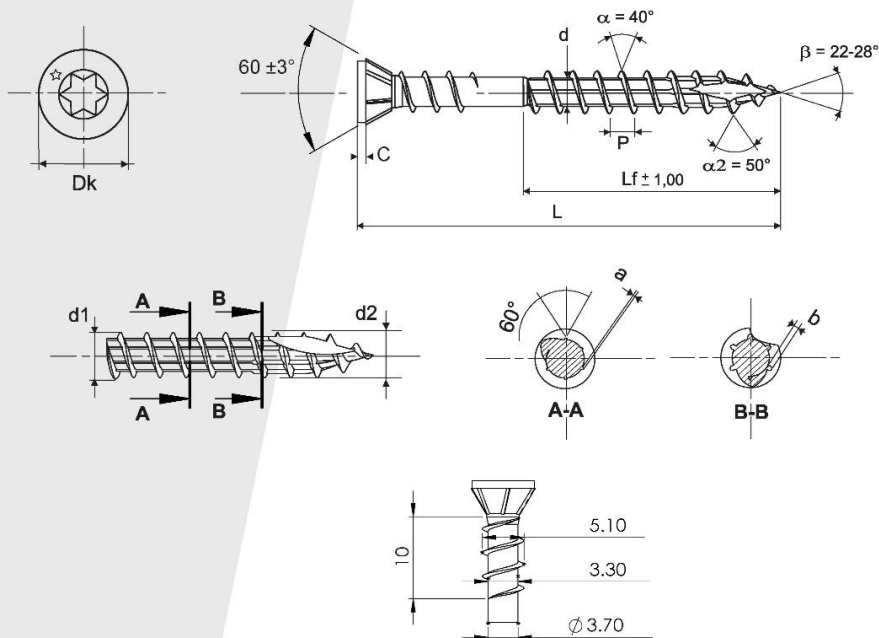

CARACTÉRISTIQUES TECHNIQUES

	Ø 5
Profondeur empreinte	1,77 mini
N° empreinte	TX 25
Dk	7,40 / 7,75
C	1,00
d	3,20 / 3,40
d1	4,95
d2	5,05
P	2,90 ± 10 %
Couple de rupture mini	7,00 Nm

Ø 5 L totale = 50 60/70

Tolérance L -1,25 L -1,50

Acier inoxydable A2